

Aliaxis UK Ltd

Dickley Lane
Lenham
Maidstone
Kent ME17 2DE

Tel: +44 (0) 330 111 4233

e-mail: studor.info@aliaxis.com

website: www.studor.net



Agrement Certificate

22/6304

Product Sheet 1

STUDOR DRAINAGE VENTILATION SYSTEMS

STUDOR MAXI-VENT AND STUDOR MINI-VENT AIR ADMITTANCE VALVES

This Agrément Certificate Product Sheet⁽¹⁾ relates to Studor Maxi-Vent and Studor Mini-Vent Air Admittance Valves, for use in above-ground drainage systems.

(1) Hereinafter referred to as 'Certificate'.

CERTIFICATION INCLUDES:

- factors relating to compliance with Building Regulations where applicable
- factors relating to additional non-regulatory information where applicable
- independently verified technical specification
- assessment criteria and technical investigations
- design considerations
- installation guidance
- regular surveillance of production
- formal three-yearly review.



KEY FACTORS ASSESSED

Drainage system design — the valves are for use in above-ground drainage systems and satisfy the performance requirements of BS EN 12380 : 2002 (see section 6).

Effect on water seals — the valves are effective in preventing the loss of water seals in appliance traps and the consequent release of foul air into a building (see section 7).

Durability — when used in the context of this Certificate, the products will not be subject to significant deterioration and will have a service life equivalent to that of the drainage system in which they are installed (see section 9).

The BBA has awarded this Certificate to the company named above for the products described herein. The products have been assessed by the BBA as being fit for their intended use provided they are installed, used and maintained as set out in this Certificate.

On behalf of the British Board of Agrément

Date of First issue: 14 November 2022

Hardy Giesler
Chief Executive Officer

The BBA is a UKAS accredited certification body – Number 113.

The schedule of the current scope of accreditation for product certification is available in pdf format via the UKAS link on the BBA website at www.bbacerts.co.uk

Readers MUST check the validity and latest issue number of this Agrément Certificate by either referring to the BBA website or contacting the BBA directly.

Any photographs are for illustrative purposes only, do not constitute advice and should not be relied upon.

British Board of Agrément

1st Floor Building 3
Hatters Lane, Croxley Park,
Watford, Herts WD18 9YG

©2022

tel: 01923 665300
clientservices@bbacerts.co.uk
www.bbacerts.co.uk

Regulations

In the opinion of the BBA, Studor Maxi-Vent and Studor Mini-Vent Air Admittance Valves, if installed, used and maintained in accordance with this Certificate, can satisfy or contribute to satisfying the relevant requirements of the following Building Regulations (the presence of a UK map indicates that the subject is related to the Building Regulations in the region or regions of the UK depicted):



The Building Regulations 2010 (England and Wales) (as amended)

Requirement: H1

Comment:

Foul water drainage

The products will:

- provide adequate ventilation to prevent the loss of water seals in trapped appliances. See sections 4, 6 and 7 of this Certificate.
- prevent foul air from entering the building. See section 7.1 of this Certificate.
- enable access to the sanitary pipework for clearing blockages. See section 6.1 of this Certificate
- contribute to the ventilation of underground drains. See sections 6.2 and 6.3 of this Certificate.

Regulation: 7(1)

Comment:

Materials and workmanship

The products are acceptable. See section 9 and the *Installation* part of this Certificate.



The Building (Scotland) Regulations 2004 (as amended)

Regulation: 8(1)

Comment:

Fitness and durability of materials and workmanship

The products can contribute to a construction satisfying this Regulation. See section 9 and the *Installation* part of this Certificate.

Regulation: 9

Standard:

Comment:

3.7(b)(c)

Building standards applicable to construction

Wastewater drainage

Sanitary pipework incorporating the products can satisfy the Requirements of this Standard, with reference to clauses 3.7.1⁽¹⁾⁽²⁾, 3.7.7⁽²⁾ and 3.7.8⁽¹⁾. See sections 4, 6 and 7 of this Certificate.

Standard:

Comment:

7.1(a)

Statement of sustainability

The products can contribute to meeting the relevant requirements of Regulation 9, Standards 1 to 6 and therefore will contribute to a construction meeting a bronze level of sustainability as defined in this Standard.

Regulation: 12

Comment:

12

Building standards applicable to conversions

Comments in relation to the products under Regulation 9, Standards 1 to 6 also apply to this Regulation, with reference to clause 0.12.1⁽¹⁾⁽²⁾ and Schedule 6⁽¹⁾⁽²⁾.

(1) Technical Handbook (Domestic).

(2) Technical Handbook (Non-Domestic).



The Building Regulations (Northern Ireland) 2012 (as amended)

Regulation: 23(1)(a)(i)

Comment:

(iii)(b)(i)

Fitness of materials and workmanship

The products are acceptable. See section 9 and the *Installation* part of this Certificate.

Regulation: 79

Comment:

79

Drainage systems

The products provide adequate ventilation to prevent the deterioration of the water seals in traps. See sections 4, 6 and 7 of this Certificate.

Construction (Design and Management) Regulations 2015 Construction (Design and Management) Regulations (Northern Ireland) 2016

In the opinion of the BBA, there is no information in this Certificate which relates to the obligations of the client, designer (including Principal Designer) and contractor (including Principal Contractor) under these Regulations.

Additional Information

NHBC Standards 2022

In the opinion of the BBA, Studor Maxi-Vent and Studor Mini-Vent Air Admittance Valves, if installed, used and maintained in accordance with this Certificate, can satisfy or contribute to satisfying the relevant requirements in relation to *NHBC Standards*, Chapter 8.1 *Internal services*.

CE marking

The Certificate holder has taken the responsibility of CE marking the products in accordance with harmonised European Standard BS EN 12380 : 2002.

Technical Specification

1 Description

1.1 Studor Maxi-Vent valve (see Figure 1) comprises an acrylonitrile-butadiene-styrene (ABS) body with integrally moulded protection screens and a synthetic rubber diaphragm and connector. The connector allows push-fitting into a 110 mm diameter pipe and over a 75 mm diameter pipe. Without the connector, the valve can be solvent welded to a 90 mm diameter socket or directly to 82 mm diameter pipe (see Table 1 and section 12.1).

1.2 Studor Mini-Vent valve (see Figure 2) comprises an ABS body with integrally moulded insect screens to a specification agreed by the BBA, and a synthetic rubber diaphragm and global connector. The connector allows push-fitting or screw connection onto waste pipes, with the sizes given in Table 1.

Figure 1 Studor Maxi-Vent Air Admittance valve

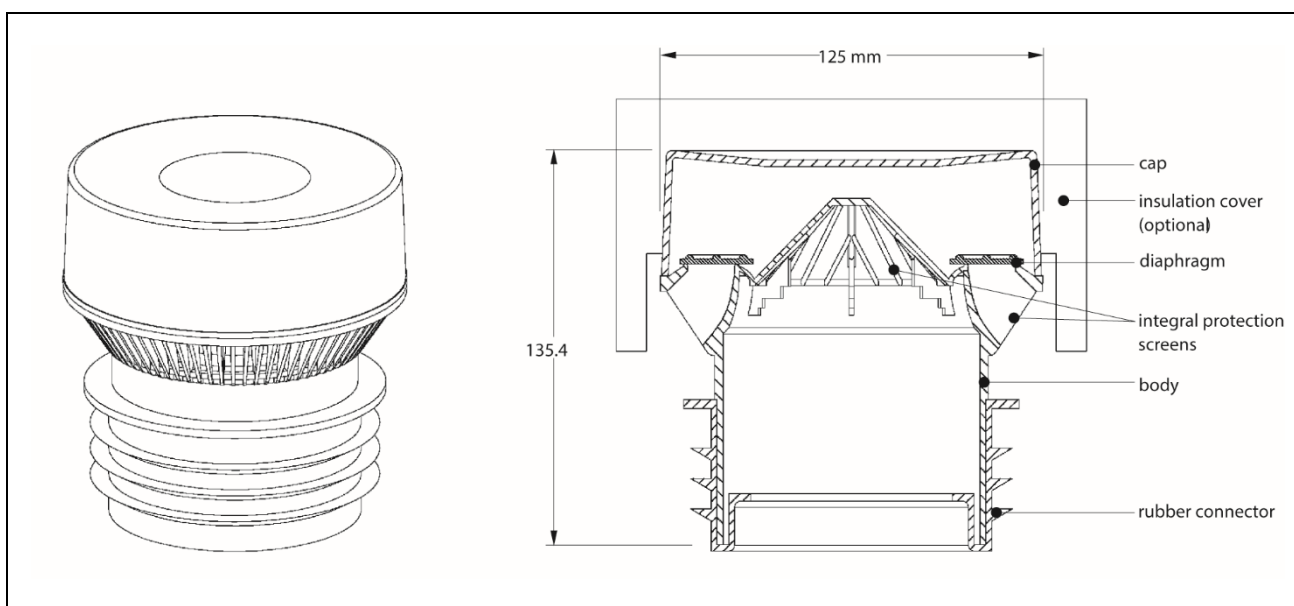

Figure 2 Studor Mini-Vent Air Admittance valve and global connector

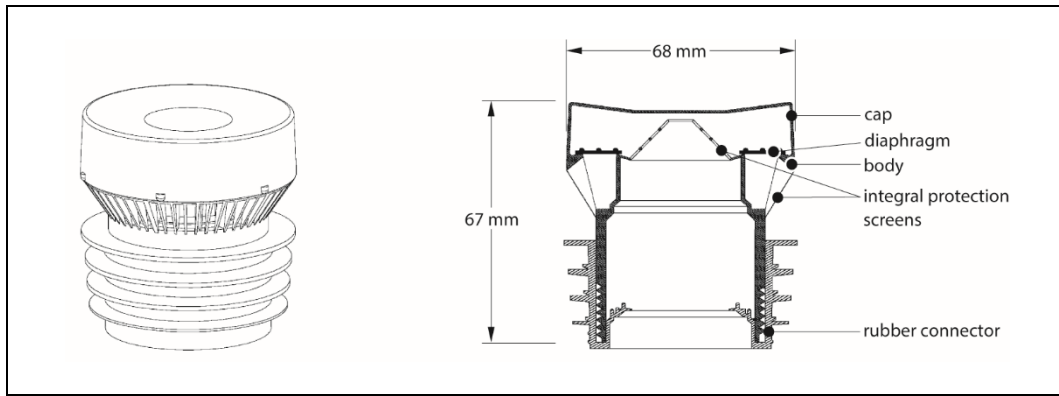

Table 1 Waste pipe dimensions for use with Studor Maxi-Vent and Studor Mini-Vent Air Admittance valves

Nominal size (mm)	Minimum mean OD (mm)	Maximum mean OD (mm)	Wall thickness (mm)		Corresponding reference	Pipe/coupler material
			Minimum	Maximum		
Studor Maxi-Vent						
75	75	75.7	1.8	3.0	BS EN 1329-1, BS EN 1451-1, BS EN 1455-1, BS EN 1519-1, BS EN 1565-1, BS EN 1566-1	Multi
82	82	82.3	3.0	3.5	BS EN 1329-1	PVC-U
90	90	90.4	1.8	3.0	BS EN 1329-1, BS EN 1451-1, BS EN 1455-1, BS EN 1519-1, BS EN 1565-1, BS EN 1566-1	Multi
110	110	110.4	2.7	3.8	BS EN 1329-1, BS EN 1451-1, BS EN 1455-1, BS EN 1519-1, BS EN 1565-1, BS EN 1566-1	Multi
75	75	75.7	1.8	3.0	BS EN 1329-1, BS EN 1451-1, BS EN 1455-1, BS EN 1519-1, BS EN 1565-1, BS EN 1566-1	Multi
Studor Mini-Vent						
32	32.3	32.3	1.8	3.0	BS EN 1451-1, BS EN 1455-1, BS EN 1565-1, BS EN 1566-1	PP, ABS, PVC
40	40.3	40.3	1.8	3.0	BS EN 1451-1, BS EN 1455-1, BS EN 1565-1, BS EN 1566-1	PP, ABS, PVC
50	50.3	50.3	1.8	3.0	BS EN 1451-1, BS EN 1455-1, BS EN 1565-1, BS EN 1566-1	PP, ABS, PVC
63	63.3	63.8	1.8	3.0	BS EN 1451-1, BS EN 1455-1, BS EN 1565-1, BS EN 1566-1	PP, ABS, PVC
34	34.4	34.8	1.8	2.2	BS EN 1451-1	PP
41	40.8	41.2	1.9	2.3	BS EN 1451-1	PP
54	53.9	54.3	2	2.4	BS EN 1451-1	PP
36	36.1	36.5	1.8	2.2	BS EN 1455-1	ABS
43	42.7	43.1	1.9	2.3	BS EN 1455-1	ABS
55	55.7	56.1	2	2.4	BS EN 1455-1	ABS
36	36.1	36.5	1.8	2.2	BS EN 1566-1	PVC-C
43	42.7	43.1	1.9	2.3	BS EN 1566-1	PVC-C
55	55.7	56.1	2	2.4	BS EN 1566-1	PVC-C

1.3 The products are designated AI in accordance with BS EN 12380 : 2002, and can be fitted below the flood level of connected appliances, in air temperatures between -20 and 60°C.

1.4 An expanded polystyrene (EPS) insulation cover may be supplied with each Studor Maxi-Vent valve as an added protection against extreme high and low temperatures and for outside installations. When used externally, the Studor Maxi-Vent valve must be fitted with an aluminium cap and the EPS cover.

1.5 The Certificate holder recommends the following ancillary items for use with the product, but these products have not been assessed by the BBA and are outside the scope of this Certificate:

- a suitable form of sound insulation, for use if the valves are to be installed in, or in close proximity to, a habitable space where noise of operation may cause a nuisance.

2 Manufacture

2.1 The body and cap of the products are manufactured from ABS using conventional injection moulding techniques. The synthetic rubber diaphragms and connectors are also injection-moulded and are push-fitted onto the ABS body.

2.2 As part of the assessment and ongoing surveillance of product quality, the BBA has:

- agreed with the manufacturer the quality control procedures and product testing to be undertaken
- assessed and agreed the quality control operated over batches of incoming materials
- monitored the production process and verified that it is in accordance with the documented process
- evaluated the process for management of nonconformities
- checked that equipment has been properly tested and calibrated
- undertaken to carry out the above measures on a regular basis through a surveillance process, to verify that the specifications and quality control operated by the manufacturer are being maintained.

2.3 The management systems of the manufacturer have been assessed and registered as meeting the requirements of BS EN ISO 9001 : 2015 by Perry Johnson Registrars, Inc (Certificate C2022-01332).

3 Delivery and site handling

3.1 Studor Maxi-Vent and Studor Mini-Vent Air Admittance Valves are shrink-wrapped and packaged in cardboard. An EPS cap may be included (see section 1.4).

3.2 The Certificate holder's legend *Studor Maxi-Vent or Studor Mini-Vent*, as appropriate, is printed on each valve cap and shown on the packaging. In addition, both valves have CE mark designation AI to BS EN 12380 : 2002 and the last two digits of the date of manufacture printed on the valve.

3.3 The BBA logo incorporating the number of this Certificate is printed on each valve.

Assessment and Technical Investigations

The following is a summary of the assessment and technical investigations carried out on Studor Maxi-Vent and Studor Mini-Vent Air Admittance Valves.

4 Use



4.1 The products, when used in accordance with the provisions of this Certificate, are satisfactory for use in above-ground drainage systems designed in accordance with BS EN 12056-1 : 2000 and BS EN 12056-2 : 2000, and will:

- admit air under conditions of reduced pressure in the discharge pipes and prevent water seals in traps from being drawn
- prevent the release of foul air from the drainage system
- contribute to the ventilation of the main drain to which the discharge stack incorporating the valve is connected.

4.2 Studor Maxi-Vent valve is for use on discharge stacks up to 45 metres or 10 storeys high.

4.3 Studor Mini-Vent valve is for use on branch discharge pipes.

4.4 Both types of valve may be used in association with each other or separately.

5 Practicability of installation

The products are designed to be installed by a competent general builder, or a contractor, experienced with these types of products.

6 Drainage system design



6.1 Drainage systems designed in accordance with BS EN 12056-1 : 2000 and BS EN 12056-2 : 2000 should be based on the airflow data given in Table 2 of this Certificate. Typical installation details in accordance with BS EN 12056-1 : 2000 are given in Figures 3 and 4 of this Certificate.

Table 2 Airflow performance

Nominal size of pipe (mm)	Airflow (litres per second)	
	Studor Mini-Vent	Studor Maxi-Vent
50	7.5	–
110	–	32.2

Figure 3 Valves installed in domestic dwellings

(a) ventilated by Studor Maxi-Vent and Mini-Vent valves

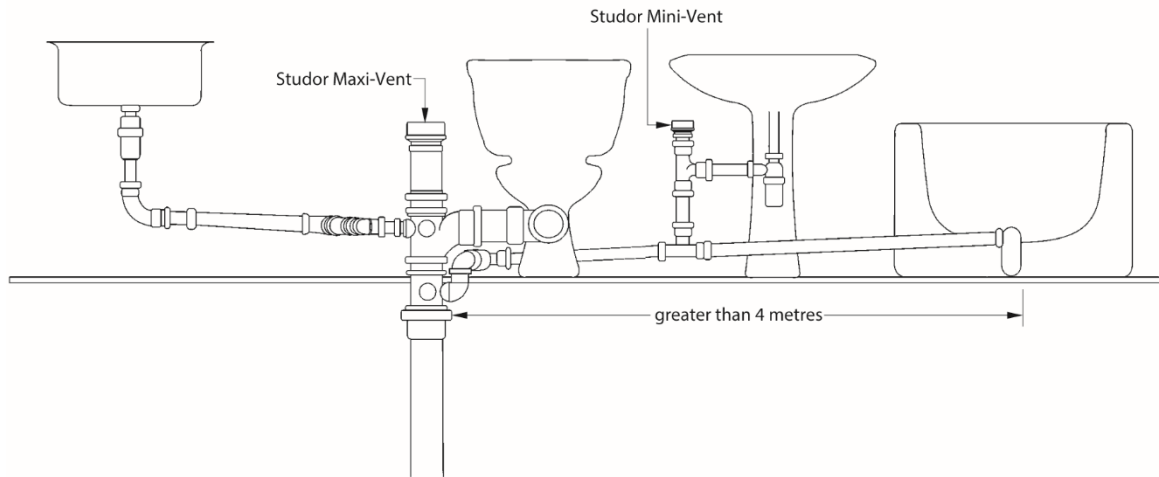

(b) unventilated

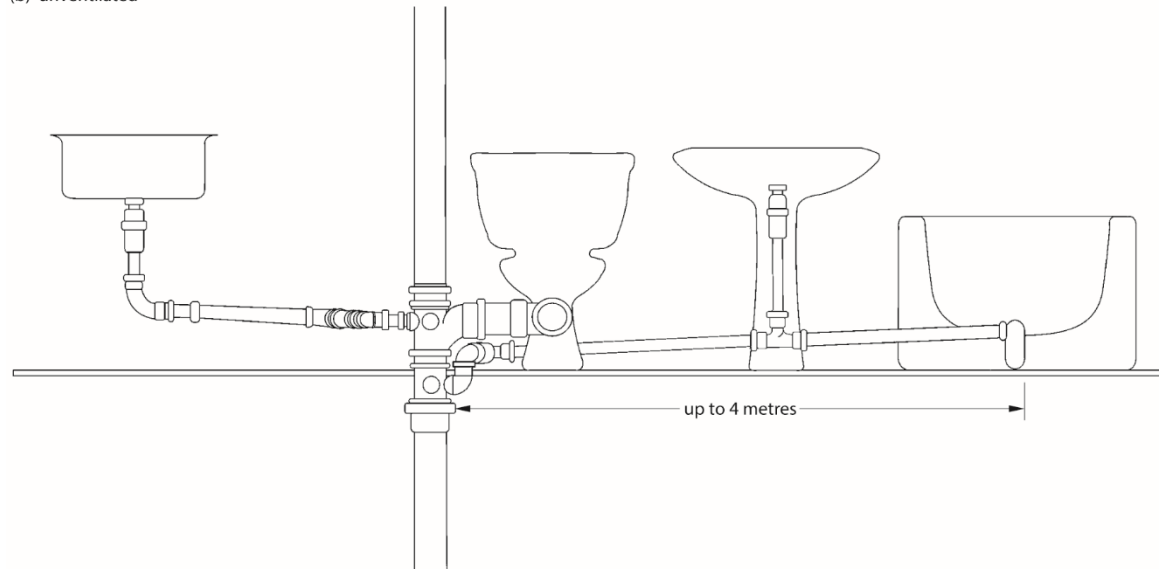

NOTES:

- The maximum distance of appliance traps from the discharge stack must be in accordance with BS EN 12056-2 : 2000, paragraph 6.4.3, Table 10 and Figure 9 Ventilated branches. The separate ventilation shown on the BS figures may be provided by a Studor Mini-Vent valve which must be within 1.5 metres of the appliance trap.
- Unventilated branches BS EN 12056-2 : 2000, paragraph 6.4.11, Table 5 and Figure 6.
- Ventilated stacks higher than 45 metres or 10 storeys must not be fitted with Studor Maxi-Vent valve as the sole means of ventilation.

Figure 4 Installation

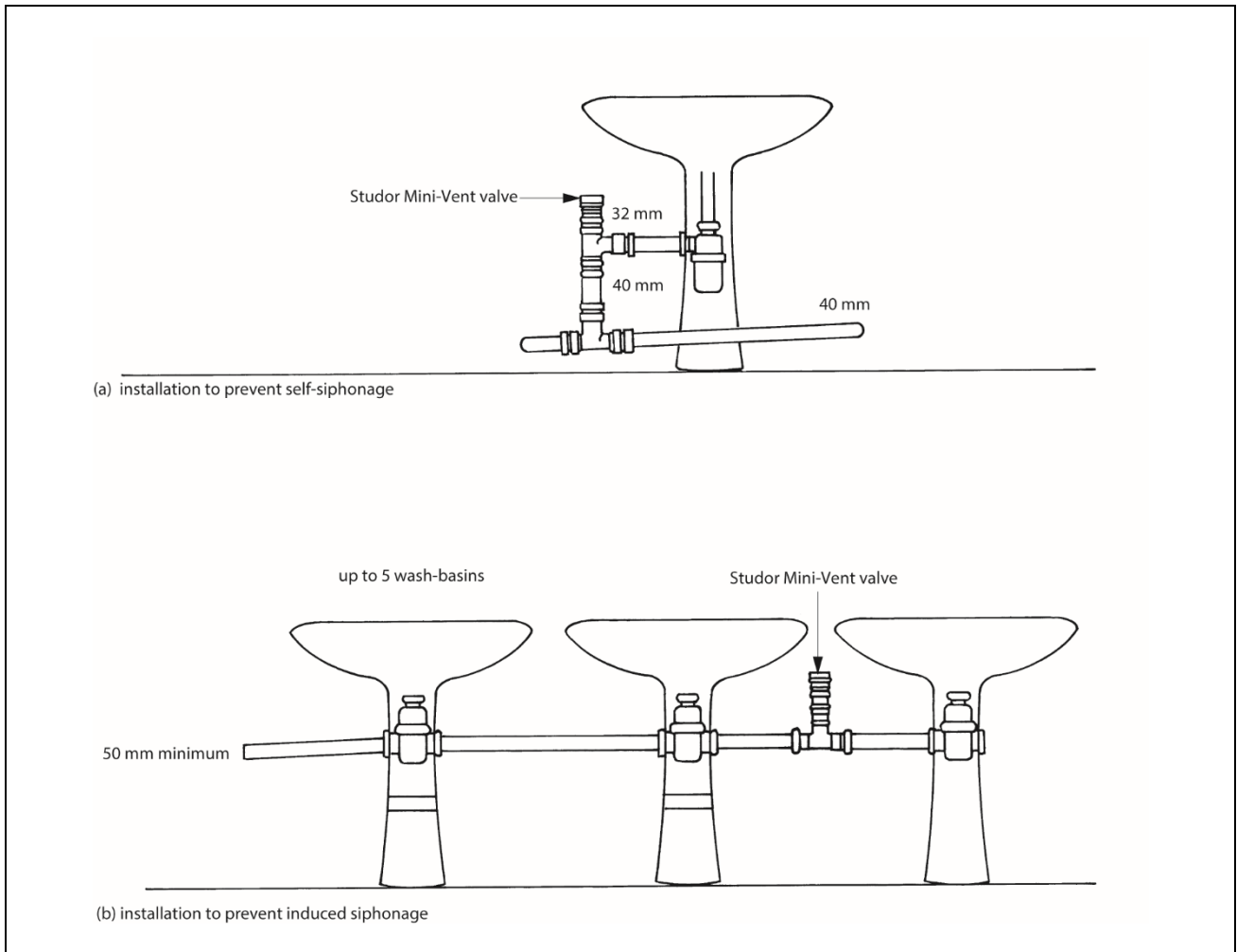

6.2 To contribute to the ventilation of the underground drain and to minimise the effects of excessive back pressures when a drain blockage occurs, the branch or main drain serving a stack or stacks fitted with the products may require venting at a point upstream of the stack connection. Guidance is given in Table 3 and Figure 5.

Table 3 Air admittance valve disposition

Number of dwellings	Up to three storeys in height	Multi-storey domestic dwellings and non-domestic buildings
1-4	Additional drain venting not required	
5-10	Conventional ventilation (open-topped or discharge stack) to be provided at the vent stack closest to the main drain sewer	Conventional drain venting to be provided if more than one such building, each equipped with the valves, is connected to a common drain which is not itself vented by means of a ventilation stack or a discharge stack not fitted with a valve
11-20	Conventional ventilation (open-topped or discharge stack) to be provided at the vent closest to the main drain sewer and at the mid-point of the system	

Figure 5 Examples of drain ventilation provisions

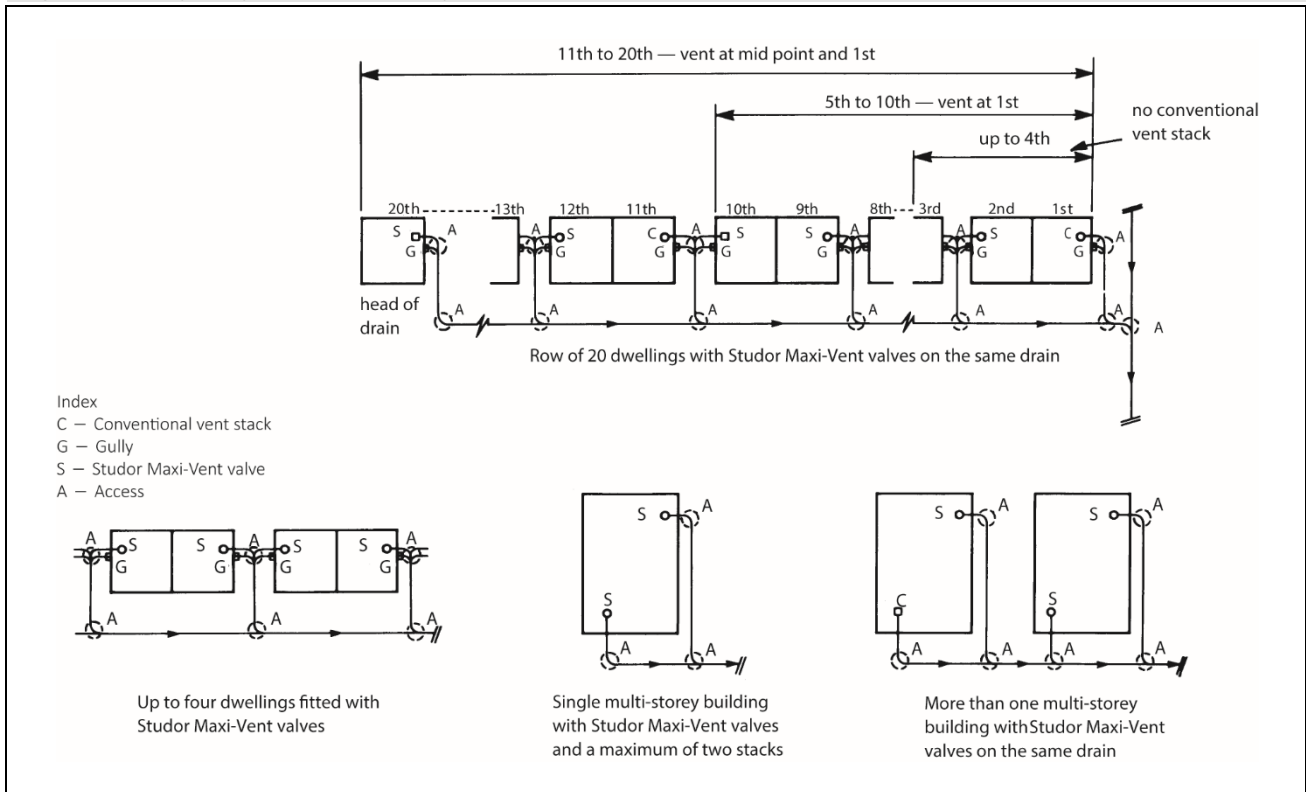

6.3 If self-siphonage is likely to occur, a connection to Studor Mini-Vent valve is required within 1500 mm of the trap (see Figure 4).

6.4 To prevent induced siphonage in a row of wash-basins, a Studor Mini-Vent valve should be fitted between the two wash basins furthest from the discharge stack (see Figure 4).

6.5 The valves should be installed within the building where they are easily accessible but not subject to interference by vandals. If fitted externally, see section 1.4.

6.6 If the valves are to be installed in, or in close proximity to, a habitable space where noise of operation may cause a nuisance, consideration must be given to the use of a suitable form of sound insulation.

6.7 In installations other than those shown in Figure 5, stacks should not be fitted with the valves when the connecting drain(s) are subject to periodic surcharging or are fitted with intercepting traps. An open-topped discharge stack or ventilating stack should be used in such cases.

6.8 The insulation cover should be used when there is a possibility that the valves may be exposed to extreme high or low temperatures. When used externally, the valves must be fitted with an optional aluminium cap, as well as the insulation cover.

6.9 Air admittance valves should not be used when the discharge stack provides the only ventilation to septic tanks or cesspools.

7 Effect on water seals



7.1 The valves will admit sufficient quantities of air into the stack when they are subjected to a reduced pressure and thereby prevent loss of the water seals in appliance traps.

7.2 Under conditions of increased pressure in the drainage system, each valve will remain closed, thereby preventing the release of foul air into the building.

7.3 A pressure increase sufficient to raise the level in the water seal or to cause foul air to bubble up through the seal is an indication that a drain blockage has occurred or that the drainage system is being overloaded or otherwise misused.

8 Maintenance

The valves do not normally require maintenance and in the event of accidental damage or vandalism, the valves must be renewed.

9 Durability



The products are manufactured from conventional drainage system materials. Repeated opening and closing will not adversely affect the sealing or operation of the valves. When used in the context of this Certificate, the products will not be subject to significant deterioration and will have a service life equivalent to that of the drainage system in which they are installed.

10 Reuse and recyclability

The products contain ABS and synthetic rubber, which can be recycled.

Installation

11 General

11.1 Installation must be carried out in accordance with the Certificate holder's instructions.

11.2 The valves are installed in discharge and/or ventilation pipes and obviate the need to penetrate the roof covering. Care should be taken to avoid contamination of the sealing surfaces, as this may affect airtightness.

11.3 Studor Maxi-Vent valve must be fitted in a vertical position 200 mm above the highest branch connection (see Figure 3) and Studor Mini-Vent valve must be fitted in a vertical position 100 mm above the pipe being ventilated (see Figure 4).

12 Procedure

12.1 Studor Maxi-Vent valve is supplied with a synthetic rubber connector enabling a push-fit into 110 mm diameter pipe and over 75 mm diameter pipe. With the connector removed, the valves can be solvent-welded onto 82 and 90 mm diameter pipe (see Table 1).

12.2 Studor Mini-Vent valve push-fit onto DN32, DN40 and DN50 pipe (see Figure 6).

Figure 6 Fitting Studor Mini-Vent valve

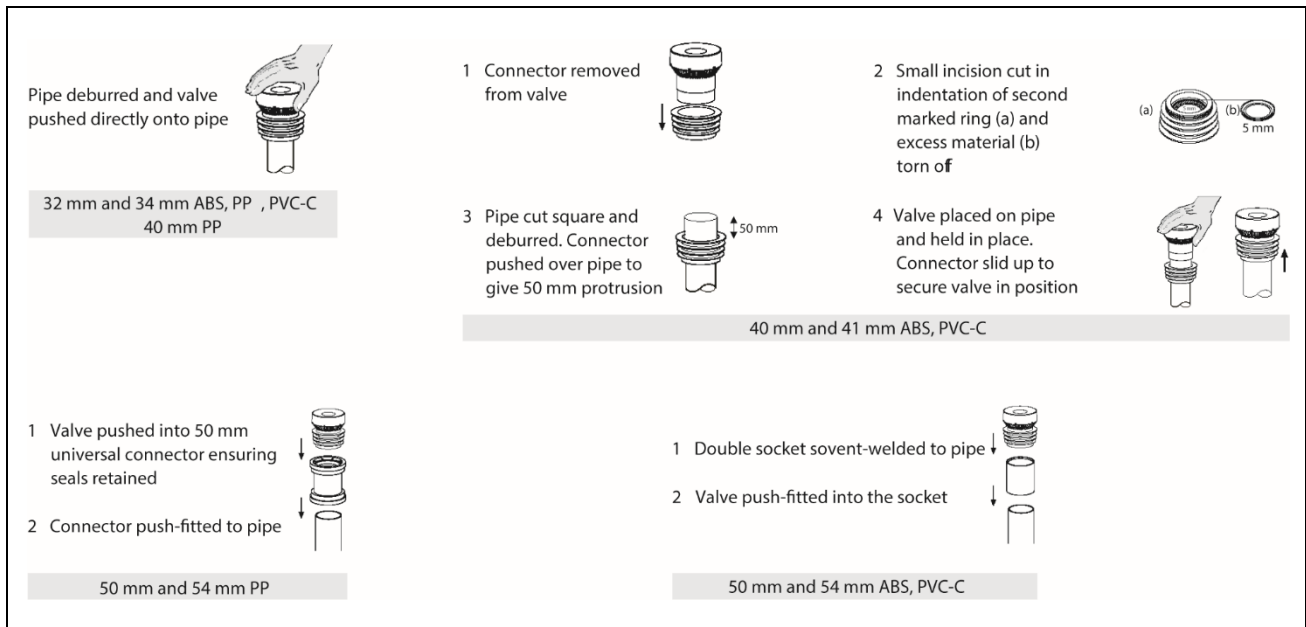

Technical Investigations

13 Tests

Tests were carried out and the results assessed to determine:

- impact resistance (drop testing)
- airtightness after endurance at negative temperature
- airtightness before and after endurance at positive temperature
- opening pressure
- airflow capacity
- peak discharge flow simulation.

14 Investigations

14.1 The manufacturing process was evaluated, including the methods adopted for quality control, and details were obtained of the quality and composition of the materials used.

14.2 A re-evaluation was made of the data on which the previous Certificate was based. The conclusions drawn from the original data remain valid.

14.3 An assessment was made of data in relation to:

- effect on trap seals when tested on five-storey test rigs
- self- and induced-siphonage
- stress relaxation
- durability.

14.4 A user survey was carried out to confirm the products' performance in use.

Bibliography

BS EN 1451-1 : 2017 *Plastics piping systems for soil and waste discharge (low and high temperature) within the building structure — Polypropylene (PP) — Specifications for pipes, fittings and the system*

BS EN 1455-1 : 2000 *Plastics piping systems for soil and waste (low and high temperature) within the building structure — Acrylonitrile-butadiene-styrene (ABS) — Specifications for pipes, fittings and the system*

BS EN 1519-1 : 2019 *Plastics piping systems for soil and waste discharge (low and high temperature) within the building structure — Polyethylene (PE) — Specifications for pipes, fittings and the system*

BS EN 1565-1 : 2000 *Plastics piping systems for soil and waste discharge (low and high temperature) within the building structure — Styrene copolymer blends (SAN + PVC) — Specifications for pipes, fittings and the system*

BS EN 1566-1 : 2000 *Plastics piping systems for soil and waste discharge (low and high temperature) within the building structure — Chlorinated poly(vinyl chloride) (PVC-C) — Specification for pipes, fittings and the system*

BS EN 1329-1 : 2020 *Plastics piping systems for soil and waste discharge (low and high temperature) within the building structure — Unplasticized poly(vinyl chloride) (PVC-U) — Specifications for pipes, fittings and the system*

BS EN 12056-1 : 2000 *Gravity drainage systems inside buildings — General and performance requirements*

BS EN 12056-2 : 2000 *Gravity drainage systems inside buildings — Sanitary pipework, layout and calculation*

BS EN 12380 : 2002 *Air admittance valves for drainage systems — Requirements, test methods and evaluation of conformity*

BS EN ISO 9001 : 2015 *Quality management systems — Requirements*

15 Conditions

15.1 This Certificate:

- relates only to the product/system that is named and described on the front page
- is issued only to the company, firm, organisation or person named on the front page – no other company, firm, organisation or person may hold or claim that this Certificate has been issued to them
- is valid only within the UK
- has to be read, considered and used as a whole document – it may be misleading and will be incomplete to be selective
- is copyright of the BBA
- is subject to English Law.

15.2 Publications, documents, specifications, legislation, regulations, standards and the like referenced in this Certificate are those that were current and/or deemed relevant by the BBA at the date of issue or reissue of this Certificate.

15.3 This Certificate will remain valid for an unlimited period provided that the product/system and its manufacture and/or fabrication, including all related and relevant parts and processes thereof:

- are maintained at or above the levels which have been assessed and found to be satisfactory by the BBA
- continue to be checked as and when deemed appropriate by the BBA under arrangements that it will determine
- are reviewed by the BBA as and when it considers appropriate.

15.4 The BBA has used due skill, care and diligence in preparing this Certificate, but no warranty is provided.

15.5 In issuing this Certificate the BBA is not responsible and is excluded from any liability to any company, firm, organisation or person, for any matters arising directly or indirectly from:

- the presence or absence of any patent, intellectual property or similar rights subsisting in the product/system or any other product/system
- the right of the Certificate holder to manufacture, supply, install, maintain or market the product/system
- actual installations of the product/system, including their nature, design, methods, performance, workmanship and maintenance
- any works and constructions in which the product/system is installed, including their nature, design, methods, performance, workmanship and maintenance
- any loss or damage, including personal injury, howsoever caused by the product/system, including its manufacture, supply, installation, use, maintenance and removal
- any claims by the manufacturer relating to CE marking.

15.6 Any information relating to the manufacture, supply, installation, use, maintenance and removal of this product/system which is contained or referred to in this Certificate is the minimum required to be met when the product/system is manufactured, supplied, installed, used, maintained and removed. It does not purport in any way to restate the requirements of the Health and Safety at Work etc. Act 1974, or of any other statutory, common law or other duty which may exist at the date of issue or reissue of this Certificate; nor is conformity with such information to be taken as satisfying the requirements of the 1974 Act or of any statutory, common law or other duty of care.