

## 5 Highrise drainage design

Emporis Standard ESN 18727 defines highrise buildings as multi-story structures between 35-100 meters tall or a building of unknown height from 12-39 floors. Skyscrapers are at least 100 meters tall.

A highrise building drainage system interconnects many separate households, floor levels and offices spaces within a single drainage system at highly elevated flow rates. Properly managing these flow rates creates exponentially bigger challenges compared to low and medium rise buildings.



Illustration 5.1

The Akatherm HDPE Single Stack Solution with stack-aerators increases performance compared to a traditional secondary ventilated system and saves valuable building space.

### 5.1 Why use the Akatherm HDPE stack-aerator

The Akatherm HDPE stack-aerator saves valuable building installation space and construction costs with increased performance and comfort.

#### Performance benefits

- It reduces the pneumatic and hydraulic pressure
- Reduces stack dimension with increased capacity compared to a secondary ventilated system
- Saves valuable building space that becomes commercially available

#### Cost benefits

- Simplified design of highrise drainage stack
- One stack-aerator offers 6 branch connections
- Saves material and installation time
- A low weight HDPE solution with welded joints for minimal maintenance
- No separate ventilation pipes reduces core drilling and fire safety solutions

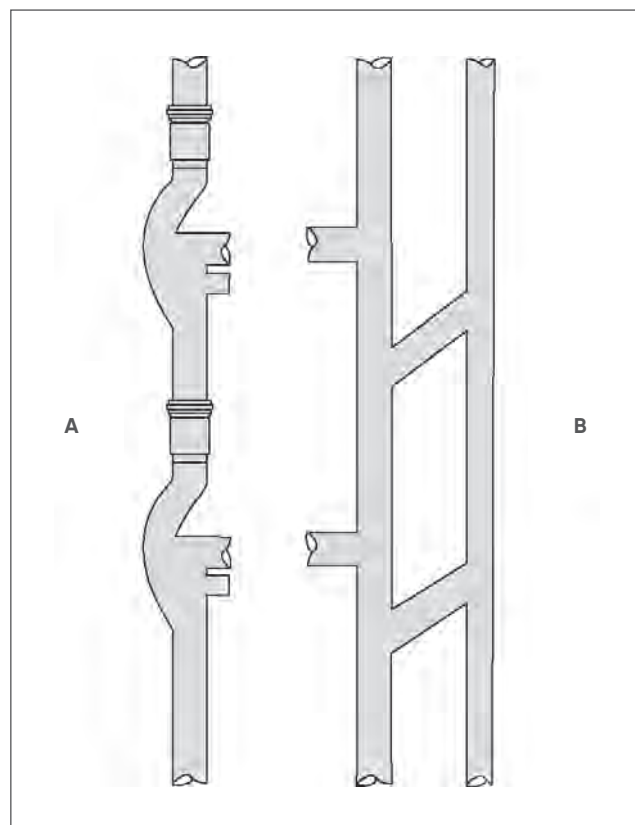

Illustration 5.2

#### Akatherm system with Akatherm HDPE stack-aerator (A)

- Single stack system
- Suited for highrise buildings
- Reduced stack dimension
- Multiple connections per branch
- Reduced velocity

#### Traditional stack with vent pipe (B)

- Two stacks
- Medium rise buildings
- Bigger diameter stack
- Multiple branches required
- High speed

## 5.2 How does the stack-aerator work

A drainage system is composed of pipes and fittings that are suited for the transport of both discharge water and air. It furthermore secures the water seal in the traps protecting the living environment against unwanted sewer gases and bacteria.

The capacity of a highrise drainage system is determined by the flow rate of the connected appliances, their simultaneous discharge pattern and the drainage design in the building.

To prevent trap seal breach the positive and negative transient pressures that exist in a highrise drainage system have to be limited.



Illustration 5.3

The unique shape of the Akatherm HDPE stack-aerator fitting reduces the speed of the falling waste water and smoothly converges the horizontal entry flow with the flow higher floors.

This maintains the core of air inside the stack and keeps the positive and negative pressures within the required limits to prevent trap seal breach, without the requirement of an additional vent pipe.

The vent opening between the offset chamber and the entry chamber keeps the horizontal pipe ventilated.

## 5.3 Akatherm HDPE stack-aerator design

The Akatherm HDPE Single Stack Solution works easily by using one Stack -aerator on each floor level. An additional ventilation pipe is not necessary. Always observe the following elements:

1. Use one stack-aerator on every floor level instead of a regular T-branch fitting.
2. The stack should be completed in one diameter, never reduced or increased in size.
3. A pressure relief line installed at the base of the stack to absorb positive pressures.
4. A vent pipe through the roof of the same diameter as the down pipe.
5. A relief vent where the stack is offset over a distance greater than 45°.

### Stack-aerator in the down pipe

The Akatherm HDPE stack-aerator must be installed on each storey with a waste water connection and when the distance between two stack-aerators is larger than 6 m. A double offset should not be used and will reduce the flow capacity (see illustration 5.4).

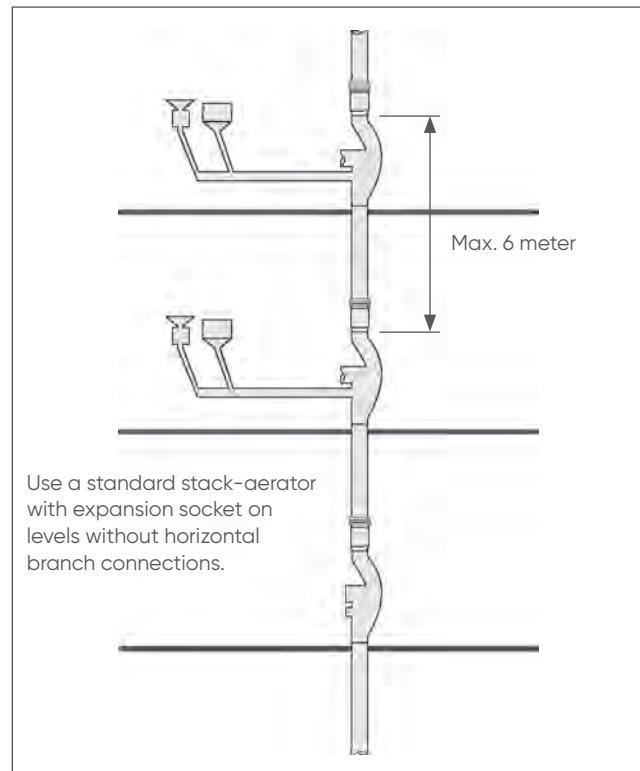

Illustration 5.4

**Zone division**

If the building design requires more than one down pipe or the maximum capacity of a single down pipe will be exceeded, the storeys must then be divided into zones, each draining into different stacks.

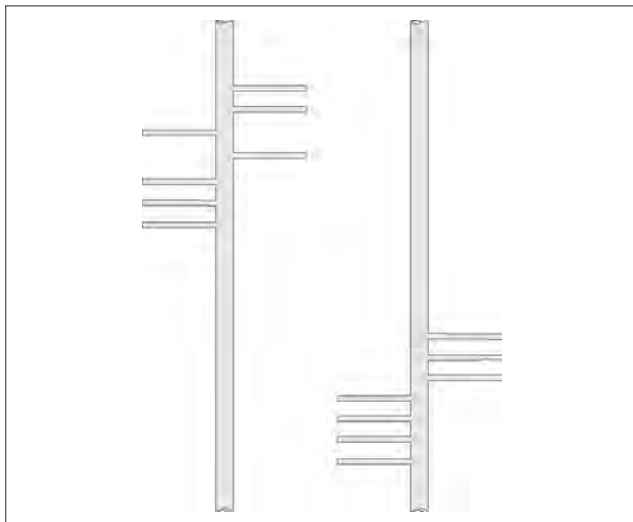

Illustration 5.5

**Deflecting the stack**

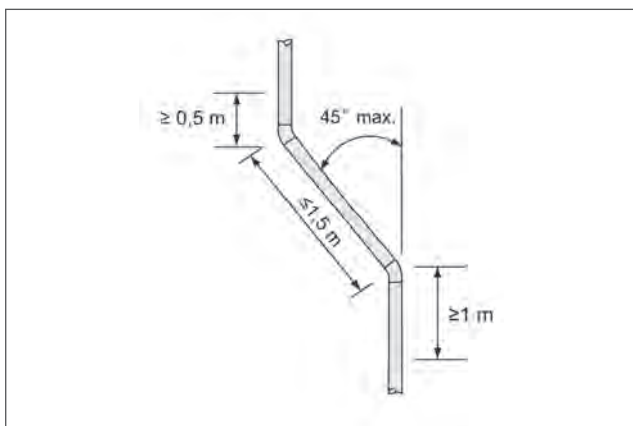

Illustration 5.6

A down pipe with stack-aerators can be deflected without use of an equalisation pipe if the transition is constructed as shown in illustration 5.6.

The angle of the offset must be 45° or less and the length of the offset pipe shorter than 1,5 m. No horizontal branch can be installed closer than 0,5 m above the offset and 1,0 beneath it.

If the axis of the down pipe with stack-aerators can't be deflected in accordance with the illustration 5.6, the offset must be equipped with an equalisation line, to be designed in accordance with illustration 5.7.

If the axis of the stack-aerator down pipe can't be deflected in accordance with the illustration 5.6, the offset must be equipped with an equalisation line, to be designed in accordance with illustration 5.7.

If collectors have to be connected at this point, these connections can be made on the equalisation pipe, which is also called a diverter. There are also joint-free zones on the diverter pipe as indicated in illustration 5.7. The equalisation or diverter pipe must have the same diameter as the down pipe.

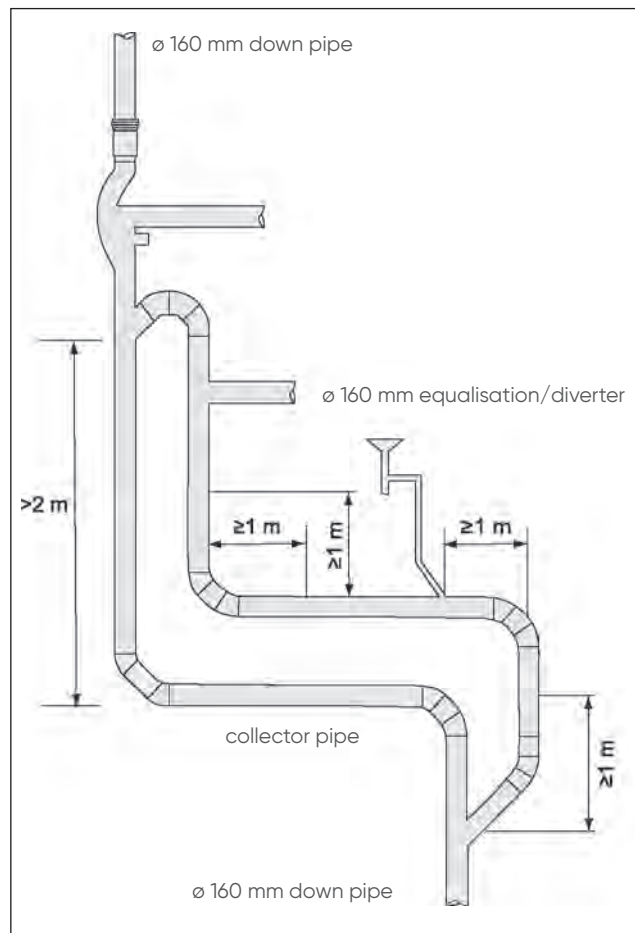

Illustration 5.7

**Horizontal branch connections**

*Unvented connections*

Unvented branch connections have a maximum length of 4 m at minimum gradient of 1,0% (1:100) with no more than three 90° bends and a maximum drop of 1,0 m. The branch connection must be sized in accordance to national standards and guidelines.

*Vented branch connections*

Vented Branch connections have a maximum length of 10 m at minimum gradient of 0,5% without bend limitation and a maximum drop of 3,0 m. The branch can be vented with pressure-relief vents connected at 45° or air admittance valves.

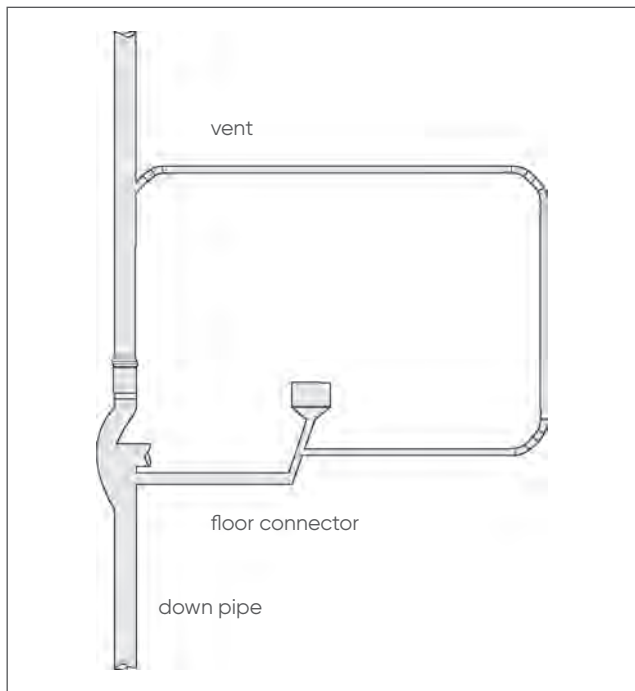

Illustration 5.8

Details about maximum total and per-storey drainage flows that may be handled by a stack-aerator down pipe can be found in paragraph 1.1.7 'System calculation'.

**!** All toilets must be connected to the stack-aerator using a 110 mm pipe. Directly opposing connections on the stack-aerator are not permitted.

**Base of the stack**

At the base of the stack a pressure relief line must be installed to absorb pressures. The ground level fixtures can be attached to the pressure relief line outside the joint-free zones. The design has to follow illustration 5.9.

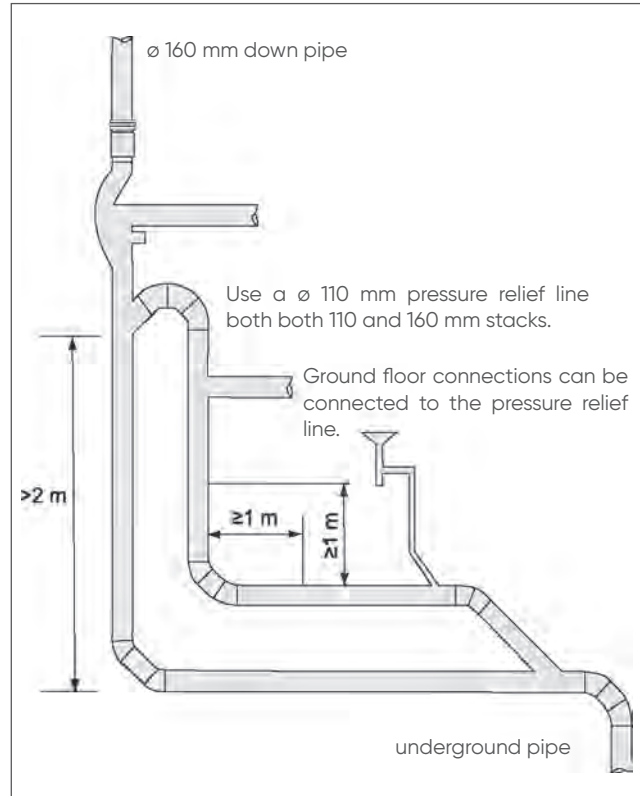

Illustration 5.9 End of the stack-aerator down pipe

**Venting the stack-aerator down pipe through the roof**

The diameter of the down pipe must remain the same without reduction until roof level is cleared. Exceptions to this rule involve the construction of multiple down pipes with a combined pressure-relief pipe. The pressure-relief pipes may be joined together beyond a point 1 m above the highest joint. For the Akatherm system, this is only permitted if the internal surface area of the combined pressure-relief line is equal to or larger than the sum of the internal surface areas of the individual pressure-relief lines.

The maximum number of combined down pipes is 3, as long as the combined pressure-relief pipe has a diameter as specified in table 5.1. Illustration 5.10 provides an example of 4 down pipes ø 110 mm with combined vent pipes.

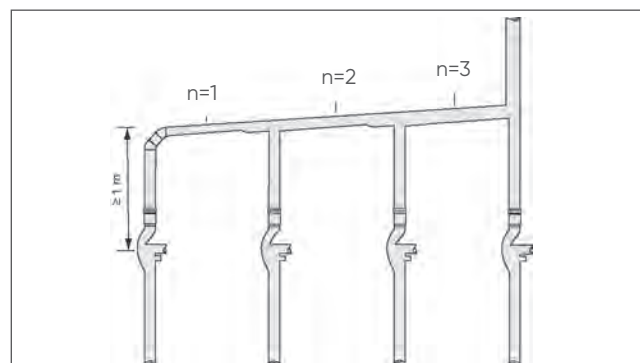

Illustration 5.10

Down pipe (n)	Minimum ø of combined pressure-relief pipe	
	Stack-aerator 110 mm	Stack-aerator 160 mm
1	110	160
2	160	250
3	200	315

Table 5.1

The position of the opening for the roof duct on the roof must be designed in accordance with national standards and guidelines, so that moisture and waste material is not allowed to enter.

Wind-shear effects can influence the pressure in the upper most section of the system. The roof penetrations should be placed as far away from the roofs edge or be protected against the wind-shear to avoid breach of traps.

**From down pipe to underground pipe**

One or more down pipes may be connected to an underground pipe provided that the capacity of the underground pipe is great enough. The maximum capacity of an underground pipe is described in EN 12056-2, and depends on the diameter and incline. The total drainage flow is the simultaneous flow from all connected drain fixtures. The relevant calculation for an underground pipe will be performed in paragraph 1.1.7.

**5.4 Stack-aerator bracketing and pipe connections**

Connections to the stack-aerator have to be butt-welded. It is strongly recommended that connections to the stack-aerator are prefabricated prior to site delivery.

Horizontal connections are best made using either Akatherm plug-in sockets or snap sockets. The snap socket offers the same convenience of the plug-in socket with a pull-tight connection, with the addition of a 'groove ring' to be applied by the plumbing contractor if required.

The stack-aerator must be fixed in place vertically to prevent any mechanical stress on the horizontal drainage pipes caused by thermal expansion and contraction of the vertical pipe system. An expansion socket on top of the stack-aerator is required to compensate for the expansion and contraction of the vertical pipe system.

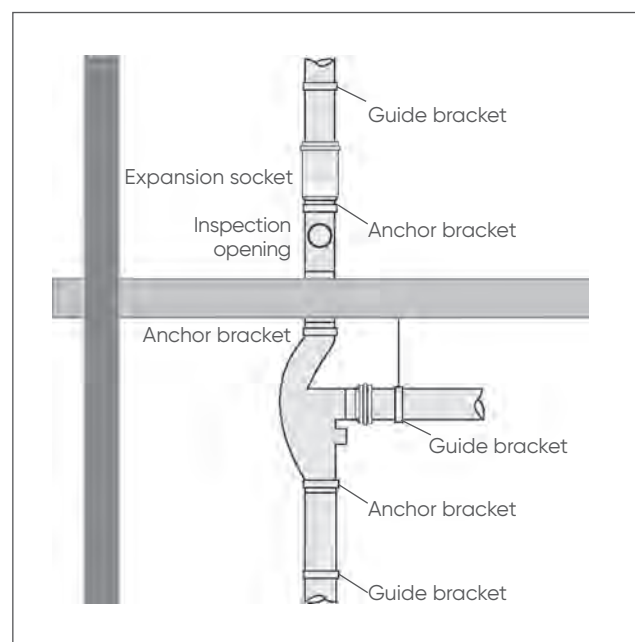

Illustration 5.11

In an underslab installation requiring penetration through a fire collar, a nominal section of pipe must be butt-welded onto the top of the stack-aerator. Take care to allow an electrofusion joint of the inspection opening and expansion socket combination above the slab.

Place anchor brackets at the expansion socket and the bottom of the stack-aerator. A slide bracket is placed at 2/3 of the pipe.

### 5.5 Duct size

The minimal duct size that is needed for a stack-aerator system can be found in table 5.2. The stack-aerator possibilities 1 and 3 are not to be used simultaneously to prevent opposing cross-flow (see illustration 5.12).

Some national standard do allow opposite connection of equally design toilet flow with a height drop in the horizontal pipe design.

	Duct size		
	only aerator 2	aerator 1 or 3	aerator 2 and (3 or 1)
110 A	300 mm	350 mm	350 mm
B	400 mm	350 mm	400 mm
160 A	270 mm	320 mm	320 mm
B	400 mm	350 mm	400 mm

Table 5.2

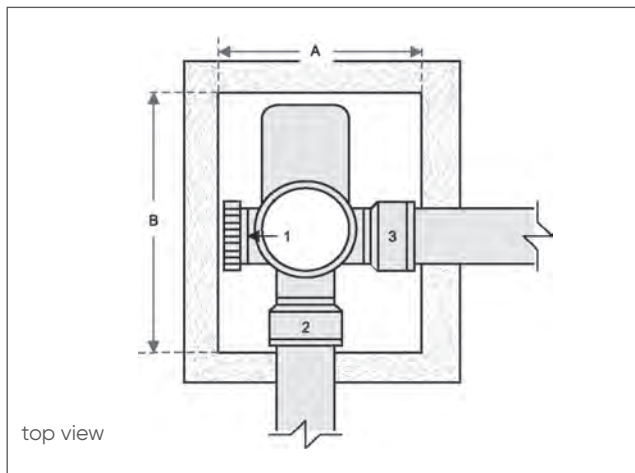

Illustration 5.12

### 5.6 Stack-aerator system calculation

The basic calculation for a stack-aerator involves determining the number of required down pipes and their diameter(s). For this purpose, the (composite) drainage flow for the collector pipes on the storeys must be compared to the maximum permissible capacity of the down pipe into which the stack-aerator is incorporated.

#### Basic drainage unit $Q_i$

The basic drainage unit ( $Q_i$ ) of each drain fixture that can be connected to a collector pipe is expressed in l/s and one  $Q$  equals 1 l/s. Table 5.3 indicates a few devices with the basic drain values according to the standard.

Drain fixture	$Q_i$ (l/s)
Sink, bidet	0,50
Washing machine, urinal	0,75
Bathtub, 70 mm floor drain	1,00
7 l toilet	2,00

Table 5.3  $Q_i$  according to EN 12056

#### Simultaneity coefficient

Not every drain fixture will be used at the same time and, therefore, the simultaneity coefficient  $p$  exists to take this factor into account. This coefficient will differ for each type of building (see table 5.4).

Type of building	$p$
Residential and similar	0,50
Detention, health care and lodging	0,70
Office, education and retail	0,70
Other uses	0,70
Sport and meeting	1,00

Table 5.4 Simultaneity coefficient

The simultaneity coefficient is employed in equation 5.1 to combine the drainage from all drain fixtures into a comparable drainage flow.

$$Q_a = p * \sqrt{\sum_{i=1}^n Q_i}$$

Equation 5.1 Combined drainage equation (l/s)

$Q_a$  = Combined simultaneous drainage (l/s)

$p$  = Simultaneity coefficient as indicated in table 1.5 ((l/s)<sup>0.5</sup>)

$n$  = Number of drain fixtures (-)

$Q_i$  = Basic drainage unit for drain fixture  $i$  as stated in table 1.4 (l/s)

In this equation, the element  $\sum_{i=1}^n Q_i$  is the combined simultaneous drainage (every drain fixture being used simultaneously).

**Akatherm HDPE stack-aerator capacity**

This combined simultaneous drainage ( $Q_a$ ) must be handled by one or more down pipes. Every down pipe incorporating the aerator has a maximum capacity based on diameter. Table 5.5 provides a summary of this.

Stack-aerator type	110 mm	160 mm
Design diameter standard (DN)	100 mm	150 mm
Maximum simultaneous drainage capacity	7,6 l/s	13,5 l/s
Max. capacity basic drainage units (Qi)*	231 l/s	729 l/s

Table 5.5 Stack-aerator capacity

\* The last row in table 5.5 shows the permitted number of basic drainage units for the down pipe. The number is calculated by re-writing equation 5.1 and by inserting the maximum capacity of the stack-aerator from table 5.5 as  $Q_a$ .

A residential building ( $p = 0,5$ ) with a single stack-aerator 110 mm down pipe can have drain fixtures with a total capacity of 231 l/s connected (see equation 5.2 for this calculation).

$$\sum_{i=1}^n Q_i = \left( \frac{Q_a}{p} \right)^2 = \left( \frac{7,6}{0,5} \right)^2$$

Equation 5.2 Re-written combined drainage equation (l/s)

This amounts to 462 bathroom sinks (basic drainage unit  $Q_i = 0,5$  l/s) or 231 bathtubs (basic drainage unit  $Q_i = 1,0$  l/s).

**Conditions affecting stack-aerator capacity**

Table 5.5 describes conditions concerning the maximum drainage flow of the collectors that may be connected to a stack-aerator down pipe in detail.

Max. capacity of one stack-aerator down pipe (l/s)	110 mm			160 mm		
	(l/s)	$Q_i$	Toilets	(l/s)	$Q_i$	Toilets
Total drainage from all floors	7,6	231	-	13,5	729	-
Toilet drainage from all floors	4,7	85	42	8,2	268	132
Total drainage from one floor	4,5	81	-	4,5	81	-
Toilet drainage from one floor	2,0	16	8	2,0	16	8

Table 5.6 Connection conditions

**Example calculation**

Calculation for a residential building with 50 floors and 4 apartments on each storey. Each apartment has drain fixtures with basic drainage units ( $Q_i$ ), which you can find in table 5.7.

Drain fixture $Q_i$	110 mm
Kitchen	1,0
Bathroom	2,5
Toilet (6 l)	2,0
Total per apartment	5,5
Total per floor	22,0
Total for building	1100

Table 5.7

In this building, the  $\sum_{i=1}^n Q_i$  is 1100 l/s and the simultaneity coefficient 0,5. The total flow  $Q_a$  is therefore:

$$Q_a = 0,5 \cdot \sqrt{1100} = 16,58 \text{ l/s.}$$

Equation 5.3

The maximum capacity for a 110 mm stack-aerator down pipe is 7,6 l/s. 3 x 110 mm stack-aerator down pipes are required or 2 x 160 mm stack-aerator down pipes having a maximum capacity of 13,5 l/s, if the conditions of the standard are to be met.

**Underground pipe calculations**

Usually, several down pipes are incorporated in a highrise building, and this combination connected to an underground pipe. The diameter of the underground pipe can be calculated in accordance with the following example.

Illustration 5.13 illustrates a situation in which the 2 down pipes in the above calculation are connected to a single underground pipe with a 1,0% gradient.

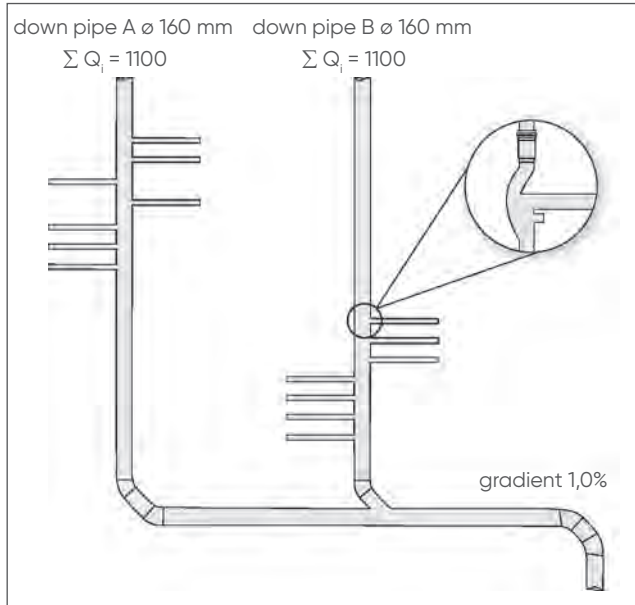

Illustration 5.13

The total capacity can be calculated by inserting the flow from all the drain fixtures into the simultaneity calculation.

$$Q_a \ 0,5 \cdot \sqrt{2200} = 23,45 \text{ l/s.}$$

Equation 5.4

The table below is a part of a table in EN 12056-2. It indicates the maximum flow per diameter and incline, based on 50% pipe filling.

Pipe ø	1:100 1,0%	1:67 1,5%	1:50 2,0%	1:40 2,5%	1:33 3,0%	1:20 5,0%
110	2,50	3,10	3,50	4,00	4,40	5,60
125	4,10	5,00	5,70	6,40	7,10	9,10
160	7,70	9,4	10,9	12,2	13,3	17,2
200	14,2	17,4	20,1	22,5	24,7	31,9
250	26,9	32,9	38,1	42,6	46,7	60,3
315	48,3	59,2	68,4	76,6	83,9	108,4

Table 5.8

The horizontal collector pipe taking the load of 11,7 l/s from stack A should continue horizontal in dimension 200 mm when installed at 1,0% gradient.

When stack B enters the horizontal collector pipe the size needs to be increased to 250 mm at 1,0 gradient to allow for the combined flow of 23,45 l/s.